



TLS 35

MICROPROCESSOR-BASED ELECTRONIC DIFFERENTIAL THERMOCONTROLLER



OPERATING INSTRUCTIONS
Vr. 02 (ENG) - 01/07 - cod.: ISTR 07307

TECNOLOGIC S.p.A.

VIA INDIPENDENZA 56
27029 VIGEVANO (PV) ITALY
TEL.: +39 0381 69871
FAX: +39 0381 698730
internet : <http://www.tecnologic.it>
e-mail: info@tecnologic.it

FOREWORD



This manual contains the information necessary for the product to be installed correctly and also instructions for its maintenance and use; we therefore recommend that the utmost attention is paid to the following instructions and to save it.

This document is the exclusive property of TECNOLOGIC S.p.A. which forbids any reproduction and divulgation, even in part, of the document, unless expressly authorized. TECNOLOGIC S.p.A. reserves the right to make any formal or functional changes at any moment and without any notice. Whenever a failure or a malfunction of the device may cause dangerous situations for persons, things or animals, please remember that the plant has to be equipped with additional devices which will guarantee safety. Tecnologic S.p.A. and its legal representatives do not assume any responsibility for any damage to people, things or animals deriving from violation, wrong or improper use or in any case not in compliance with the instrument's features.

INDEX

- 1 INSTRUMENT DESCRIPTION
 - 1.1 GENERAL DESCRIPTION
 - 1.2 FRONT PANEL DESCRIPTION
- 2 PROGRAMMING
 - 2.1 PROGRAMMING OF SET POINT
 - 2.2 STANDARD PARAMETERS PROGRAMMING
 - 2.3 RAPID PROTECTION OF THE PARAMETERS USING A PASSWORD
 - 2.4 PROGRAMMING CUSTOM PARAMETERS AND THE PARAMETER PROGRAMMING LEVELS
 - 2.5 ON / STAND-BY FUNCTION
 - 2.6 MANUAL FORCING OF THE OUT OUTPUT
- 3 INFORMATION ON INSTALLATION AND USE
 - 3.1 PERMITTED USE
 - 3.2 MECHANICAL MOUNTING
 - 3.3 ELECTRICAL CONNECTIONS
 - 3.4 ELECTRICAL WIRING DIAGRAM
- 4 FUNCTIONS
 - 4.1 MEASURING AND VISUALIZATION
 - 4.2 OUTPUTS CONFIGURATION
 - 4.3 DIFFERENTIAL TEMPERATURE REGULATOR AND DESCRIPTION OF TWO TYPICAL APPLICATIONS
 - 4.3.1 SOLAR COLLECTORS (THERMAL SOLAR PANELS)
 - 4.3.2 CHILLER (FLUID COOLERS)
 - 4.4 OUTPUT ACTIVATION DELAY FUNCTIONS
 - 4.5 ALARM FUNCTIONS
 - 4.6 DIGITAL INPUT
 - 4.7 PARAMETERS CONFIGURATION BY KEY01
- 5 PROGRAMMABLE PARAMETERS TABLE
- 6 PROBLEMS, MAINTENANCE AND GUARANTEE
 - 6.1 SIGNALLING
 - 6.2 CLEANING
 - 6.3 GUARANTEE AND REPAIRS
- 7 TECHNICAL DATA
 - 7.1 ELECTRICAL DATA
 - 7.2 MECHANICAL DATA
 - 7.3 MECHANICAL DIMENSIONS
 - 7.4 FUNCTIONAL DATA
 - 7.5 INSTRUMENT ORDERING CODE

1 - INSTRUMENT DESCRIPTION

1.1 - GENERAL DESCRIPTION

The model TLS 35 is an microprocessor-based electronic differential thermocontroller and is typically used to control thermal solar panel plants but can also be used in all applications that require a control function for temperature differences between two different environments as for example fluid coolers (chiller), natural climatization systems for environments by air recirculation and many other applications.

The instrument has up to 3 relay outputs, two inputs for PTC or NTC temperature probes and a digital input, that can all be configured.

The 3 outputs can be used for controlling the temperature control device (OUT), and to operate depending on the programmable alarm thresholds and referring to the measurements of the two probes (AL1, AL2).

1.2 - FRONT PANEL DESCRIPTION

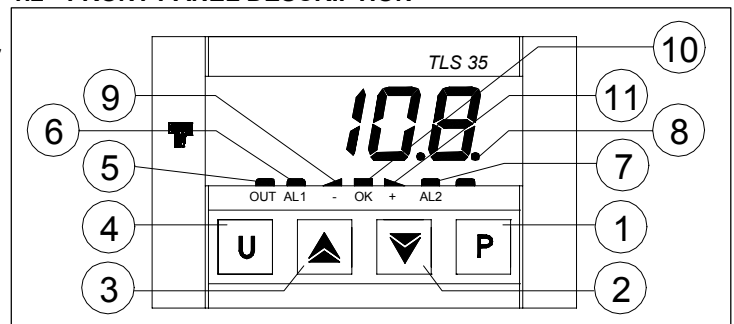

1 - P Key: Used to set the Set point and to programme the functional parameters

2 - DOWN Key: Used to decrease the setting values. It can also be used to force deactivation of the OUT output if the function is enabled by the "Fbud" parameter.

3 - UP Key: Used to increase the setting values and to select parameters. It can also be used to force activation of the OUT output if the function is enabled by the "Fbud" parameter. In programming mode it can be used together with the P key to change the programming level of the parameters.

4 - U Key: Used to display the temperature measured by the probes (Pr1 and Pr2) and the difference between the two (Pr1-Pr2). It can also be programmed by using the "USrb" parameter to turn on or turn off (stand-by) the instrument. **5 - OUT Led:** Indicates the state of the regulation output: on (turned on), off (turned off) or inhibited (flashing)

6 - AL1 Led: Indicates the active state of alarm AL1.

7 - AL2 Led: Indicates the active state of alarm AL2.

8 - SET Led: Indicates entering the programming mode and parameter programming level. It is also used to indicate the Stand-by state.

9 - Led - : Indicates a low temperature alarm condition.

10 - Led OK: Indicates that no alarms are present

11 - Led +: Indicates a high temperature alarm condition.

2 - PROGRAMMING

2.1 - PROGRAMMING OF THE SET POINT

Press the key **P** then release it and the display will show "SPd" alternating with the set value.

To change it press the UP key to increase the value or DOWN to decrease it.

These keys increase or decrease the value one digit at a time, but if the button is pressed for more than one second the value increase or decreases rapidly, and after two seconds pressed, the speed increases even more to all the desired value to be reached rapidly.

Exiting the Set mode is achieved by pressing the P key or automatically if no key is pressed for 15 seconds. After that time the display returns to the normal function mode.

2.2 - STANDARD PARAMETER PROGRAMMING

To access the functional parameters of the instrument when parameter protection is not active, press the **P** key for about 5 seconds. The screen will display the code that identifies the first parameter and using the UP or DOWN keys, it is possible to select the parameter to be edited.

Once the required parameter has been selected, press the P key and the parameter code and setting will be displayed. The setting can be modified using the UP or DOWN keys.

Set the desired value and press the P key again: the new value will be stored and the display will show only the identification of the parameter selected.

Acting on the UP or DOWN keys another parameter can be selected and changed as described above.

To exit programming mode do not touch any key for about 20 seconds, or press the U key for about 1 second until programming mode exits.

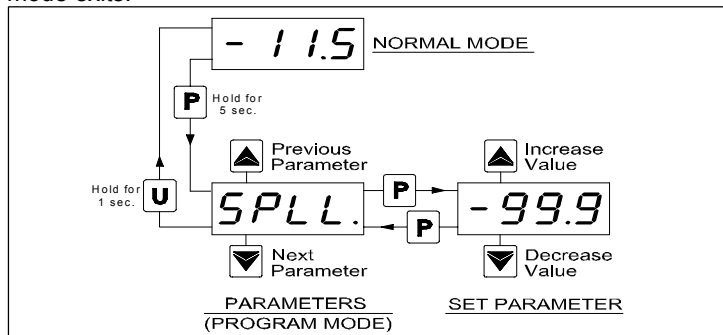

2.3 - RAPID PROTECTION OF THE PARAMETERS USING A PASSWORD

The instrument is provided with a function for the protection of the parameters using a custom password through the "PASS" parameter.

If the user wishes to use this protection, set the "PASS" parameter, the desired password number and exit the programme.

When the protection is activated, to have access to the parameters press the P key for about 3 seconds. The screen will display the password request "r.PAS" and by pressing the P key again the screen will display "0".

At this point set the password number using the UP and DOWN keys and press the P key

If the password is correct the screen will display the identification code of the first parameter and the parameters can be programmed using the same methods described in the previous paragraph.

The password protection is disabled by setting the "PASS" parameter equal to OFF.

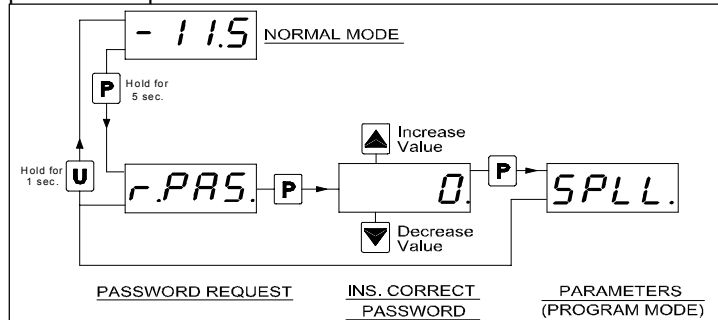

2.4 - PROGRAMMING CUSTOM PARAMETERS AND THE PARAMETER PROGRAMMING LEVELS

The instrument factory setting for password protection acts on all parameters.

Once the password is enabled using the "PASS" parameter, the user may require to free some parameters from the protection whilst maintaining some parameters protected. To do this, see the following procedure.

Access programming through the password procedure and select the parameter that can be programmed without a password.

Once the parameter has been selected check the SET led, if this led is flashing this means that the parameter can only be programmed under password protection and is therefore "protected" (if the led is on, the parameter can be programmed without a password and is therefore "not protected").

To change parameter visibility keep the P key pressed and press the UP key also.

The SET led will change its state indicating a new access level for the parameter (on = not protected; flashing = protected by password).

In the case that Password is enabled and if some parameters are changed to "not protected", when programming mode is accessed the "not protected" parameters will be displayed first" and for last the "r.PAS" parameter which can be used to access the "protected" parameters.

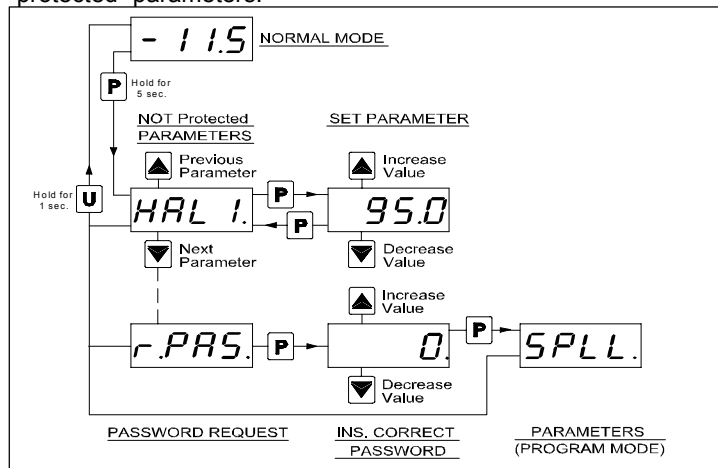

NOTE: If the password is lost, cut-off power to the instrument, press the P key and give power back to the instrument whilst keeping the key pressed for about 5 seconds.

This will give access to all parameters and it will be possible to check and change the "PASS" parameter.

2.5 - ON / STAND-BY FUNCTION

The instrument, once powered up, can assume 2 different conditions:

- ON : means that the controller uses the control functions.

- STAND-BY : means that the controller does not use any control function and the display is turned off except for the green SET led. If there is no power, and then power returns, the system always sets itself in the condition it was in before the black-out.

The ON/Stand-by function can be selected using the key U if the parameter "USrb" = 1.

2.6 - MANUAL FORCING OF THE OUT OUTPUT

To be able to check the plant functions, the instrument can manually actuate the differential regulator output.

The function to manually force the output is enabled by programming the parameter "Fbud" =1

Once the function is enabled, force the output by pressing for about 5 seconds the UP key (forced activation) or DOWN (forced deactivation).

Forcing is displayed on the screen alternatively to normal display by an "On" message (forcing activated) or an "OFF" message (forcing deactivated).

To exit forcing mode, again press quickly one of the UP or DOWN keys.

3 - INFORMATION ON INSTALLATION AND USE



3.1 - PERMITTED USE

The instrument has been projected and manufactured as a measuring and control device to be used according to EN61010-1 for the altitudes operation until 2000 ms. The use of the instrument for applications not expressly permitted by the

above mentioned rule must adopt all the necessary protective measures. The instrument CANNOT be used in dangerous environments (flammable or explosive) without adequate protection. The installer must ensure that EMC rules are respected, also after the instrument installation, if necessary using proper filters. Whenever a failure or a malfunction of the device may cause dangerous situations for persons, thing or animals, please remember that the plant has to be equipped with additional devices which will guarantee safety.

3.2 - MECHANICAL MOUNTING

The instrument, in case 4 DIN Modules, is designed for mounting on DIN OMEGA rail.

Avoid placing the instrument in environments with very high humidity levels or dirt that may create condensation or introduction of conductive substances into the instrument.

Ensure adequate ventilation to the instrument and avoid installation in containers that house devices which may overheat or which may cause the instrument to function at a higher temperature than the one permitted and declared.

Connect the instrument as far away as possible from sources of electromagnetic disturbances such as motors, power relays, relays, solenoid valves, etc.

3.3 - ELECTRICAL CONNECTION

Carry out the electrical wiring by connecting only one wire to each terminal, according to the following diagram, checking that the power supply is the same as that indicated on the instrument and that the load current absorption is no higher than the maximum electricity current permitted.

As the instrument is built-in equipment with permanent connection inside housing, it is not equipped with either switches or internal devices to protect against overload of current: the installation will include an overload protection and a two-phase circuit-breaker,

placed as near as possible to the instrument, and located in a position that can easily be reached by the user and marked as instrument disconnecting device which interrupts the power supply to the equipment.

It is also recommended that the supply of all the electrical circuits connected to the instrument must be protect properly, using devices (ex. fuses) proportionate to the circulating currents.

It is strongly recommended that cables with proper insulation, according to the working voltages and temperatures, be used.

Furthermore, the input cable of the probe has to be kept separate from line voltage wiring. If the input cable of the probe is screened, it has to be connected to the ground with only one side.

Whether the instrument is 12 V version it's recommended to use an external transformer TCTR, or with equivalent features, and to use only one transformer for each instrument because there is no insulation between supply and input.

We recommend that a check should be made that the parameters are those desired and that the application functions correctly before connecting the outputs to the actuators so as to avoid malfunctioning that may cause irregularities in the plant that could cause damage to people, things or animals.

3.4 - ELECTRICAL WIRING DIAGRAM

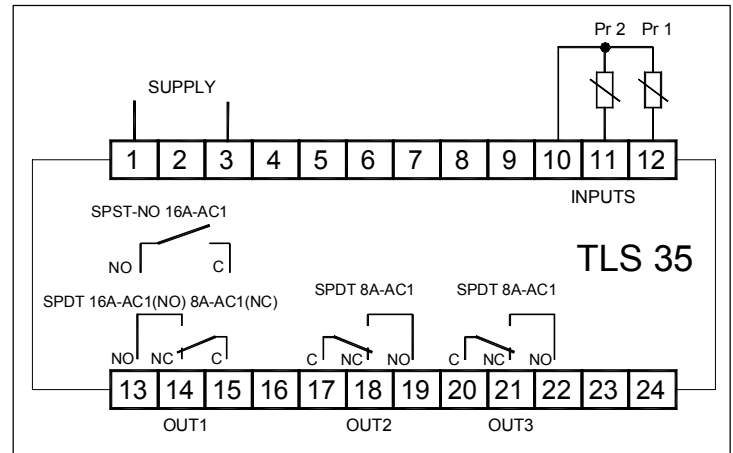

4 - FUNCTIONS

4.1 - MEASURING AND VISUALIZATION

Via the parameter "SenS" it is possible to select the type of probes that one wishes to use and which can be: thermistores PTC KTY81-121 (Ptc) or NTC 103AT-2 (ntc). Once the type of probe used has been selected, through the parameter "Unit", it is possible to select the temperature unit of measurement (°C or °F) and, through the parameter "dP", the resolution of the desired measurement (OFF=1°; On =0,1°). The instrument allows the measuring to be calibrated, that can be used for re-calibrating the instrument according to application needs, through the parameters "OFS1" (for the probe Pr1) and "OFS2" (for the probe Pr2). Using the parameter "FIL", it is possible to set the time constant for the software filter for measuring the input values to be able to reduce the sensitivity to measurement disturbances (increasing the time). Through the paragraph "diSP", it is possible to fix the normal visualisation on the display that can be the measurement of probe Pr1 (Pr 1), the measurement of probe Pr2 (Pr 2), the temperature difference of Pr1-Pr2 (P1-2), the set point of the differential regulation (SPd) or the numeric display can be set off (OFF). Independently of how the "diSP" parameter is set, it is possible to display all variables in a round-robin configuration by pressing and releasing the U key, the screen will display the code that identifies the variables (Pr 1, Pr 2, P1-2) and the variable value. This display mode is terminated automatically after about 15 seconds from the last time the U key was pressed. If an error on one of the probes occurs, the instrument deactivates the OUT output and, if the user desires, switch the alarm output/s chosen according to the values programmed into the "EAL" parameter (0 = no action; 1 =switch the AL1 output; 2 =switch the AL2 output; 3 = switch both the AL1 and AL2 outputs).

4.2 - OUTPUTS CONFIGURATION

The instrument outputs can be configured using parameters "Out1", "Out2" and "Out3".

The outputs can be configured for the following functions:

= **Out** - To command the temperature control device

= **AL1** - To command a device that can be activated depending on the AL1 alarm using a normally open or closed contact in an alarm condition.

= **AL2** - To command a device that can be activated depending on the AL2 alarm using a normally open or closed contact in an alarm condition.

= **-AL1** - To command a device that can be activated depending on the AL1 alarm using a normally open or closed contact in an alarm condition.

= **-AL2** - To command a device that can be activated depending on the AL2 alarm using a normally open or closed contact in an alarm condition.

= **OFF** - Output disabled

4.3 - DIFFERENTIAL TEMPERATURE REGULATOR AND DESCRIPTION OF TWO TYPICAL APPLICATIONS

The differential regulation of the instrument is an ON/OFF type and acts on the output configured as "Out" depending on the temperature difference between the probe Pr1 and the probe Pr2, the Set Point "SPd", the intervention hysteresis "HSET" and the function mode "Func".

The regulator operates on the Out output to maintain a difference between Pr1-Pr2 equal to the value of "SPd".

The function mode "Func" = Cool is used for applications where the action of the actuator decreases the difference Pr1-Pr2 (therefore opposing the difference Pr1-Pr2 that naturally tends to increase).

Vice versa the mode "Func" = HEAT is used for applications where the action of the actuator increases the difference Pr1-Pr2 (therefore opposing the difference Pr1-Pr2 that tends to decrease).

4.3.1 - SOLAR COLLECTORS (THERMAL SOLAR PANELS)

The most common application that uses a differential regulator is for the operational functions of solar collector plants with a forced circulation heat exchanger.

These plants are made up of a hydraulic circuit containing solar panels and a heat exchanger placed in a water accumulation tank. Control can be actuated by a cooling action ("Func" = Cool), in fact the output is actuated when the temperature difference is more than a determined value (practically the action foresees cooling of the liquid in the collector).

The instrument measures the temperature that the liquid reaches at the output of the solar panels (probe Pr1) and the temperature of the liquid in the final part of the heat exchanger (probe Pr2).

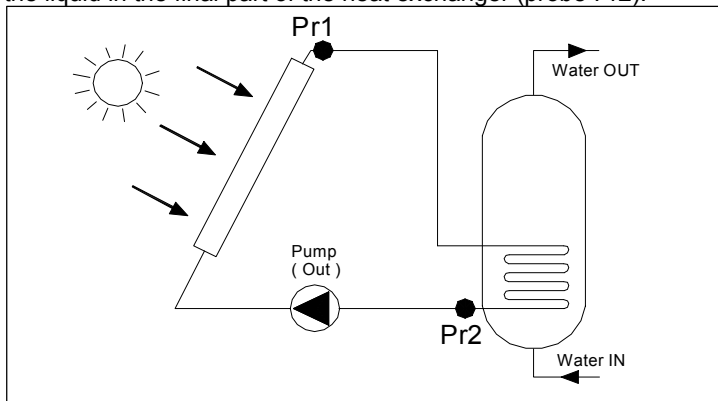

If the liquid in the panels (Pr1) is hotter than the liquid in the heat exchanger of the tank (Pr2) a temperature difference (Pr1-Pr2) is higher than the value [SPd+HySt] and the instrument activates the output configured as **Out** that commands a pump and circulates the liquid in the heat exchanger circuit.

During the time the pump is functioning heat exchange occurs and the temperature difference will obviously tend to 0.

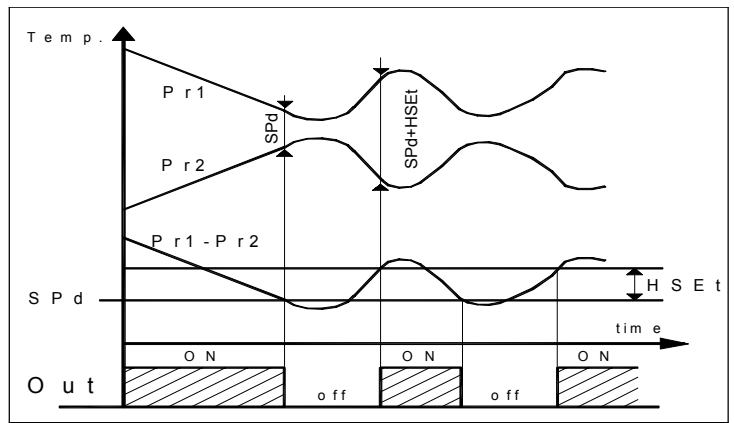

Once the temperature difference set by "SPd" is reached, the Out output is turned off.

The value Set will be the temperature difference estimated by the user to allow enough heat transfer from the heat exchanger fluid to the water in the accumulation tank and therefore exploit the thermal energy produced by the panel.

4.3.2 - CHILLER (FLUID COOLERS)

The same type of action ("Func" = Cool) is also used to control a heat exchanger circuit with a cooling actuator, as for example a Chiller through which the water leaving is cooled with respect to the water entering, therefore maintaining a negative temperature difference ("SPd" will be set with negative values).

In this application the probe Pr1 will be placed in a position to measure the outlet temperature from the chiller and the probe Pr2 placed to measure the inlet temperature.

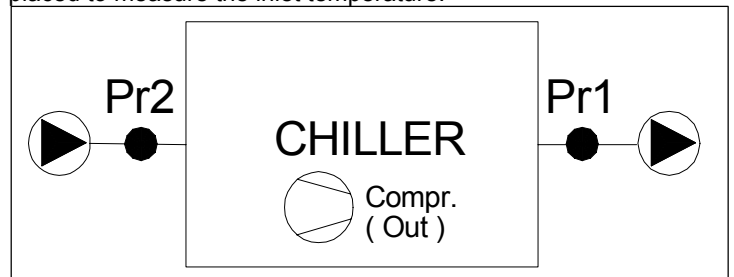

If the outlet water temperature (Pr1) is equal to or more than the inlet temperature (Pr2) a temperature difference (Pr1-Pr2) is higher than the value [SPd+HySt] and the instrument activates the output configured as **Out** when commanding a refrigeration system cools the outlet water from the chiller.

During the function of the refrigeration system the temperature measured by the Pr1 probe will tend to decrease. Once the temperature difference set by "SPd" is reached, the Out output is turned off.

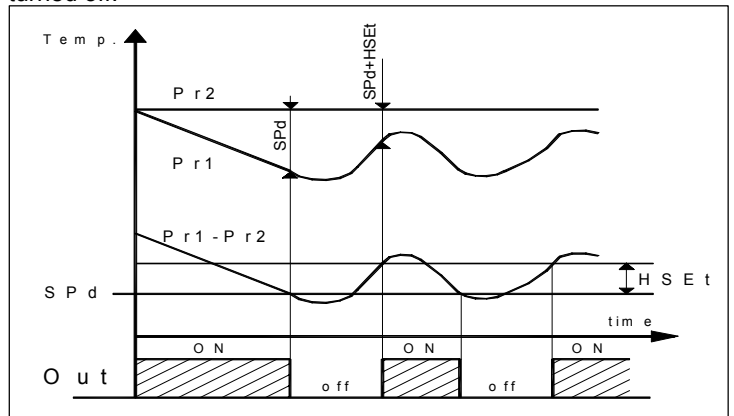

4.4 - OUTPUT ACTIVATION DELAY FUNCTIONS

The instrument allows three time controls for the activation of the Out output.

The first control sets a delay for output activation equal to the time set in the "Ptd" parameter.

The second control inhibits the output activation if the time set in the "PtS" parameter has not passed.

The last and third control sets the minimum activation time for the OUT output using the "Ltc" parameter, to avoid too short turn on times of the actuator controlled by the instrument.

These functions can be useful to avoid frequent interventions of the outputs especially when the outputs command compressors or other motors in general.

If during the delay phases the requests of the regulator are lost, the output actuation is naturally cancelled.

The delay functions are deactivated by setting the relative parameters to = OFF.

During the delay phases, the relative output led is flashing to signal the protection in effect.

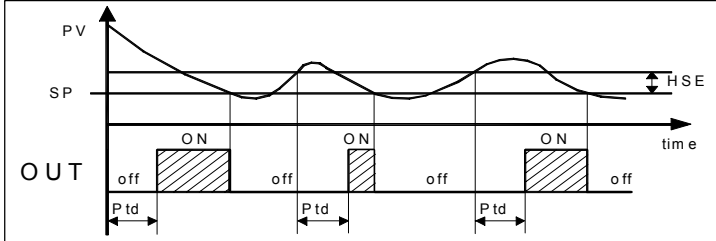

"Ptd" example with "Func" = Cool

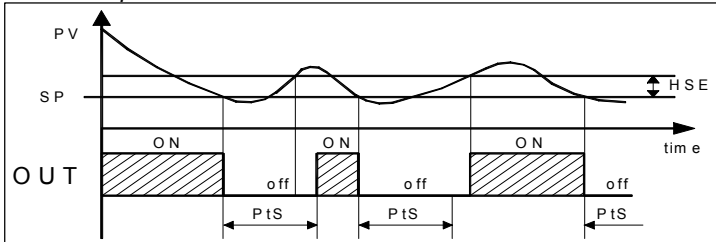

"Pts" example with "Func" = Cool

It is also possible to prevent activation of all the outputs after the instrument is turned on, for the time set in the parameter "od".

The function is disabled by "od" = OFF.

During the power on delay phase, the display shows the indication **od**, alternating with the normal programmed visualisation.

4.5 - ALARM FUNCTIONS

The instrument has 2 absolute alarm thresholds (maximum and minimum) for each of the two probes and some parameters to be able to determine how the outputs are behaving to the alarm interventions.

The alarms act according to the measurements of the probes (Pr1 e Pr2), to the alarm thresholds set for "HAL1" parameter (maximum alarm referring to Pr1), "LAL1" (minimum alarm referring to Pr1), "HAL2" (maximum alarm referring to Pr2), "LAL2" (minimum alarm referring to Pr2) and the relative intervention differentials "dAL1" and "dAL2".

Using some of the parameters it is possible to delay enabling and the intervention of these alarms.

These parameters are:

"PAL" – it is the exclusion time of all temperature alarms from turning on the instrument in the case that the instrument is in an alarm condition when it is turned on.

"ALd1" – it is the delay time for temperature alarms actuation referring to the probe Pr1

"ALd2" - it is the delay time for temperature alarms actuation referring to the probe Pr2

Furthermore, the temperature alarms have a function of activation on time and programmable through the parameters "ALt1" (for the alarms of Pr1 probe) and "ALt2" (for the alarms of Pr2 probe).

This function allows to establish the minimum and maximum time of commutation of the alarm output.

In the practice, at the intervention of the alarm, the programmed outputs are commuted and they remain like that for the programmed time, independently by the state of the alarm during the counting.

Insofar, if the alarm is always present during the counting, the programmed time will be the maximum time of commutation.

If instead the alarm had to disappear during the counting, the programmed alarm outputs won't commute and the programmed time will be then the minimum time of commutation.

The start of the activation timer happens therefore at the intervention of the alarm, the timer is active independently by the state of alarm, while the reset of the timer will happen at the end of the time if the alarm is no longer present or at the disappearance of the alarm if the time is ended.

The function is disabled programming the parameters "ALt1" and "ALt2" = OFF.

The instrument allows the configuration of 2 alarm outputs (AL1 e AL2) operating with closure logic (AL1, AL2) or opening logic (-AL1, -AL2).

When temperature alarms intervene the instrument commutes the configured alarm outputs and signals on the screen, alternately to the normal display of the variable set by the "diSP" parameter:

"HI 1" for the maximum alarm 1

"LO 1" for the minimum alarm 1

"HI 2" for the maximum alarm 2

"LO 2" for the minimum alarm 2

Using some parameters ("OHA1", "OLA1", "OHA2" and "OLA2") it is possible to set the behaviour of the regulation output Out when an alarm is generated (0 = no action, 1 = activate the output Out ; 2 = deactivate the output Out)

Whilst using other parameters ("AHA1", "ALA1", "AHA2" and "ALA2") it is possible to set the behaviour of the two alarm outputs AL1 and AL2 (0 = no action; 1 = Commute only output AL1 ; 2 = Commute only output AL2 ; 3 = Commute both outputs AL1 and AL2).

As it is possible to have two alarms at the same time, one alarm referring to the probe Pr1 and another alarm referring to the probe Pr2, and it is possible to programme disagreeing actions for the output Out (parameters "OLA1", "OHA1", "OLA2", "OHA2"), using the parameter "ALP" it is possible to set the priority action of the alarm on the output Out (1 = alarms priority Pr1 ; 2 = alarms priority Pr2).

The alarm outputs can only operate on temperature alarm functions (therefore they can be used to intervene automatically on the plant carrying out a foreseen function), however they can intervene to signal measurement errors.

Using the "EAL" parameter it is possible to set the behaviour of the two alarm outputs AL1 and AL2 in the case of probe errors (so that not only temperature error signals are given but also system malfunctions can be signalled).

Knowing that there are many exceptions, the following situations describe some particular cases that are used for alarm functions in a typical application to control solar panels.

The following diagram illustrates a typical application where the alarm output AL1 can be used (diagram used in cases A3, B2, C2).

The alarm output AL2 can also be used and the designer of the plant can use this output to construct more complete and complex applications.

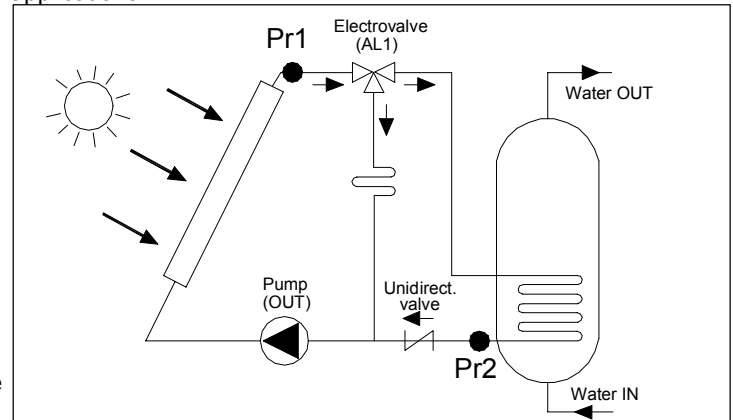

Case A – Minimum alarm on probe Pr1 (Anti-ice on the solar collector)

During the winter the temperature of the solar collector liquid could fall to a very low value. In this case it is possible to use the minimum alarm measured by the probe Pr1 whose threshold can be set by the "LAL1" parameter.

When this alarm intervenes the instrument can:

1) Activate the outlet of the circulation pump independently of the differential regulator until the temperature Pr1 rises above the value

[LAL1+ALd1]. In this case heat transfer will be from the tank heat exchanger to the solar panel. ("OLA1" = 1)

2) Deactivate the circulation pump independently of the differential regulator (because the liquid is considered too cold to be sent to the heat exchanger) until the temperature Pr1 rises above the value [LAL1+ALd1]. ("OLA1" = 2)

3) Activate the circulation pump outlet independently of the differential regulator and the alarm output (e.g. AL1) that can be used to commute a 3-way valve deviating the fluid flow towards an external heat exchanger instead of towards the tank heat exchanger until the temperature Pr1 rises above the value [LAL1+ALd1].

In this case the alarm output could be used to command a heating actuator (electrical resistance or any other device). ("OLA1" = 1; "ALA1" = 1)

Case B – Maximum alarm on probe Pr2 (Overheating of the water heat exchanger)

During the summer the liquid temperature in the heat exchanger could rise bringing the water temperature in the tank to a value too high. It is possible to use the maximum alarm measured by the probe Pr2 whose threshold can be set by the "HAL2" parameter.

When this alarm intervenes the instrument can:

1) Interrupt circulation pump operation independently of the differential regulator (therefore interrupting heat exchange) until the temperature Pr2 descends under the value [HAL2-ALd2]. ("OHA2" = 2)

2) Activate the circulation pump outlet independently of the differential regulator and the alarm output (e.g. AL1) that can be used to commute a 3-way valve deviating the fluid flow towards an external heat exchanger instead of towards the tank heat exchanger until the temperature Pr2 descends below the value [HAL2-ALd2].

In this case the alarm output could be used to command a cooling actuator (ventilator or any other device). ("OHA2" = 1; "AHA2" = 1)

Case C - Maximum alarm on probe Pr1 (Overheating of the solar collector)

During the summer the liquid temperature in the solar collector could rise bringing the liquid temperature to a value too high. It is possible to use the maximum alarm measured by the probe Pr1 whose threshold can be set by the "HAL1" parameter.

When this alarm intervenes the instrument can:

1) Interrupt circulation pump operation independently of the differential regulator (because the liquid is considered too hot to be sent to the heat exchanger) until the temperature Pr1 descends below the value [HAL1-ALd1]. ("OHA1" = 2)

2) Activate the circulation pump outlet independently of the differential regulator and the alarm output (e.g. AL1) that can be used to commute a 3-way valve deviating the fluid flow towards an external heat exchanger instead of towards the tank heat exchanger until the temperature has not descended below the value [HAL1-ALd1]. This function is the same as case B2 for heat exchanger overheating. ("OHA1" = 1; "AHA1" = 1)

Case D - Minimum alarm on probe Pr2 (Anti-ice on the water heat exchanger)

This is a rare case as usually the water tank of forced circulation plants is normally placed inside the building and in most cases an actuator for post-heating of the water is provided (practically a second heating element to the solar energy).

For this reason the temperature measured by the probe Pr2 in the water heat exchanger should never descend to a temperature near to 0°C.

However, if the plant foresees the post-heating operation in a different tank or in other particular cases (e.g. breakdown of the plant during the winter) it is possible to use the minimum alarm measured by the probe Pr2 whose threshold can be set by the "LAL2" parameter.

When this alarm intervenes the instrument can:

1) Interrupt circulation pump operation independently of the differential regulator (as the fluid circulating is too cold) until the temperature Pr2 rises above the value [LAL2+ALd2]. ("OLA2" = 2)

2) Interrupt circulation pump operation independently of the differential regulator and activate the alarm output (e.g. AL1) using this to activate a heating actuator (electrical resistance or any other

device) until the temperature Pr2 rises above the value [LAL2+ALd2]. ("OLA2" = 2; "ALA2" = 1)

3) Activate the circulation pump outlet and the alarm output (e.g. AL1) that can be used to commute a 3-way valve deviating the fluid flow towards an external heat exchanger instead of towards the solar collector until the temperature Pr2 rises above the value [LAL2+ALd2].

In this case the alarm output could be used to command a heating actuator (electrical resistance or any other device). ("OLA2" = 1; "ALA2" = 1)

NOTE: In this last case the application diagram will be similar to the one illustrated but with a 3-way valve placed on the pump outlet and a non-return valve placed on the solar collector outlet.

4.6 - DIGITAL INPUT

The digital input present on the instrument accepts contacts free of voltage, the function carried out is defined by the parameter "diF" and the action can be delayed for the time set in parameter "did".

The parameter "diF" can be configured for the following functions:

= 0 - Digital input not active

= 1 - External AL1 alarm signal with contact normally open: on closing the input the instrument visualises **AL** and the variable set in parameter "diSP" alternately on the display and switch the AL1 configured output.

= 2 - External AL2 alarm signal with contact normally open: on closing the input the instrument visualises **AL** and the variable set in parameter "diSP" alternately on the display and switch the AL2 configured output.

= 3 - External AL1 and AL2 alarm signal with contact normally open: on closing the input the instrument visualises **AL** and the variable set in parameter "diSP" alternately on the display and switch the AL1 and AL2 configured outputs.

= 4 - External AL1 alarm signal with disablement of the control output (OUT) with contact normally open: on closing the input the control output is disabled, the AL1 configured output is switched and the instrument visualises **AL** and the variable set in parameter "diSP" alternately on the display.

= 5 - External AL2 alarm signal with disablement of the control output (OUT) with contact normally open: on closing the input the control output is disabled, the AL2 configured output is switched and the instrument visualises **AL** and the variable set in parameter "diSP" alternately on the display.

= 6 - External AL1 and AL2 alarm signal with disablement of the control output (OUT) with contact normally open: on closing the input the control output is disabled, the AL1 and AL2 configured outputs are switched and the instrument visualises **AL** and the variable set in parameter "diSP" alternately on the display.

= -1, -2, -3, -4, -5, -6 - Similar to the previous but with function logic reversed (contact normally closed)

4.7 - PARAMETERS CONFIGURATION BY "KEY01"

The instrument is equipped with a connector that allows the transfer from and toward the instrument of the functioning parameters through the device **TECNOLOGIC KEY01** with **5 poles** connector.

This device it's mainly useable for the serial programming of the instruments which need to have the same parameters configuration or to keep a copy of the programming of an instrument and allow its rapid retransmission.

To use the device KEY01 it's necessary that the device or instrument are being supplied.

Instrument supplied and device not supplied

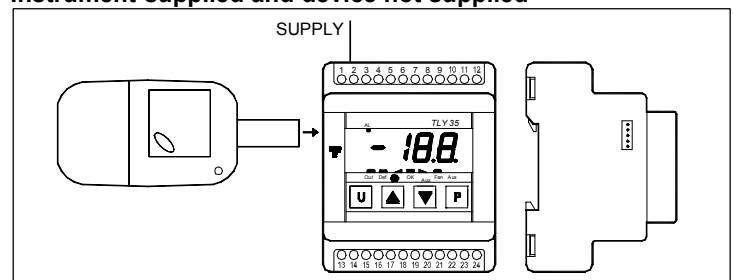

Instrument supplied from the device

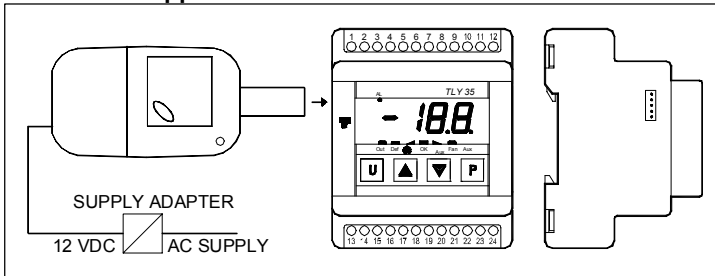

For additional info, please have a look at the KEY01 instruction manual.

5 - PROGRAMMABLE PARAMETERS TABLE

Here following are described all the parameters available on the instrument. Some of them could be not present or because they are depending on the type of instrument or because they are automatically disabled as unnecessary.

| Par. | Description | Range | Def. | Note |
|------|--|------------------------|-------|------|
| 1 | SPLL Minimum Set Point | -99.9 ÷ SPHL | -99.9 | |
| 2 | SPHL Maximum Set Point | SPLL ÷ 99.9 | 99.9 | |
| 3 | SEnS Probe type | Ptc - ntc | Ptc | |
| 4 | OFS1 Pr1 probe calibration | -30.0 ÷ 30.0 °C/°F | 0.0 | |
| 5 | OFS2 Pr2 probe calibration | -30.0 ÷ 30.0 °C/°F | 0.0 | |
| 6 | Unit Unit of measure | °C - °F | °C | |
| 7 | dP Decimal point | On - OFF | On | |
| 8 | FIL Measurement filter | OFF ÷ 20.0 sec | 2.0 | |
| 9 | Func Differential regulator functioning mode: Cool= Cooling (direct action) HEAt= Heating (reverse action) | HEAt / Cool | Cool | |
| 10 | HSEt Differential regulator hysteresis | 0.0 ÷ 30.0 °C/°F | 2.0 | |
| 11 | Ptd OUT output activation delay | OFF ÷ 99.59 min.sec | OFF | |
| 12 | PtS OUT output activation delay after turning off | OFF ÷ 99.59 min.sec | OFF | |
| 13 | LtC OUT output minimum operating time | OFF ÷ 99.59 min.sec | OFF | |
| 14 | od Outputs actuation delay when turned on | OFF ÷ 99.59 min.sec | OFF | |
| 15 | HAL1 Pr1 alarm threshold for high temperature | OFF / - 58 ÷ 302 °C/°F | OFF | |
| 16 | LAL1 Pr1 alarm threshold for low temperature | OFF / - 58 ÷ 302 °C/°F | OFF | |
| 17 | dAL1 HAL1 and LAL1 alarm hysteresis | 0 ÷ 30 °C/°F | 1.0 | |
| 18 | ALd1 HAL1 and LAL1 alarm delay | OFF ÷ 99.59 min.sec | OFF | |
| 19 | ALt1 Activation time Alarms HAL1 and LAL1 | OFF ÷ 99.59 min.sec | OFF | |
| 20 | OHA1 Action of the HAL1 alarm on the OUT output: 0 = no action 1 = Activate the OUT output 2 = Deactivate OUT output | 0 / 1 / 2 | 0 | |
| 21 | OLA1 Action of the LAL1 alarm OUT output: 0 = no action 1 = Activate the OUT output | 0 / 1 / 2 | 0 | |

| | | | | |
|----|-------------|---|------------------------|-----|
| | | 2 = Deactivate OUT output | | |
| 22 | AHA1 | Action of the HAL1 alarm on the alarm outputs: 0 = no action 1 = Commute the AL1 output only 2 = Commute the AL2 output only 3 = Commute both the AL1 and AL2 outputs | 0 / 1 / 2 / 3 | 0 |
| 23 | ALA1 | Action of the LAL1 alarm on the alarm outputs: 0 = no action 1 = Commute the AL1 output only 2 = Commute the AL2 output only 3 = Commute both the AL1 and AL2 outputs | 0 / 1 / 2 / 3 | 0 |
| 24 | HAL2 | Pr2 alarm threshold for high temperature | OFF / - 58 ÷ 302 °C/°F | OFF |
| 25 | LAL2 | Pr2 alarm threshold for low temperature | OFF / - 58 ÷ 302 °C/°F | OFF |
| 26 | dAL2 | Pr2 temperature alarm hysteresis | 0 ÷ 30 °C/°F | 1.0 |
| 27 | ALd2 | Pr2 temperature alarm delay | OFF ÷ 99.59 min.sec | OFF |
| 28 | ALt2 | Activation time Alarms HAL2 and LAL2 | OFF ÷ 99.59 min.sec | OFF |
| 29 | OHA2 | Action of the HAL2 alarm on the OUT output: 0 = no action 1 = Activate the OUT output 2 = Deactivate OUT output | 0 / 1 / 2 | 0 |
| 30 | OLA2 | Action of the LAL2 alarm on the OUT output: 0 = no action 1 = Activate the OUT output 2 = Deactivate OUT output | 0 / 1 / 2 | 0 |
| 31 | AHA2 | Action of the HAL2 alarm on the alarm outputs: 0 = no action 1 = Commute the AL1 output only 2 = Commute the AL2 output only 3 = Commute both the AL1 and AL2 outputs | 0 / 1 / 2 / 3 | 0 |
| 32 | ALA2 | Action of the LAL2 alarm on the alarm outputs: 0 = no action 1 = Commute the AL1 output only 2 = Commute the AL2 output only 3 = Commute both the AL1 and AL2 outputs | 0 / 1 / 2 / 3 | 0 |
| 33 | ALP | Alarm priority when forcing the Out output | 1 / 2 | 1 |
| 34 | EAL | Probes error action on the alarm outputs: 0 = no action | 0 / 1 / 2 / 3 | 0 |

| | | | | | |
|----|-------------|---|---|------|--|
| | | 1 = Commute the AL1 output 2 = Commute the AL2 output 3 = Commute both the AL1 and AL2 outputs | | | |
| 35 | PAL | Temperature alarm exclusion time after turning on | OFF ÷ 24.00 hrs.min | OFF | |
| 36 | USrb | U key function mode: 0= no action 1= ON/STAND-BY | 0 / 1 | OFF | |
| 37 | Fbud | UP and DOWN keys function mode: 0 = no action 1 = Manually force OUT output | 0 / 1 | 1 | |
| 38 | diSP | Variable displayed normally on the screen: OFF=Screen switched off Pr1= Pr1probe measurement Pr2= Pr2 probe measurement P1-2= Difference between Pr1- Pr2 SPd= Differential Set Point | OFF / Pr1 / Pr2 / P1-2 / SPd | P1-2 | |
| 39 | Out1 | OUT1 output configuration | OFF / Out / AL1 / AL2 / -AL1 / -AL2 | Out | |
| 40 | Out2 | OUT2 output configuration | OFF / Out / AL1 / AL2 / -AL1 / -AL2 | AL1 | |
| 41 | Out3 | OUT3 output configuration | OFF / Out / AL1 / AL2 / -AL1 / -AL2 | AL2 | |
| 42 | diF | Function and function logic of digital input: 0 = No function 1 = Alarm AL1 2 = Alarm AL2 3 = Alarm AL1 and AL2 4 = Alarm AL1 and Out disable 5 = Alarm AL2 and Out disable = 6 - Alarm AL1, AL2 and Out disable | -6 / -5 / -4 / -3 / -2 / -1 / 0 / 1 / 2 / 3 / 4 / 5 / 6 | 0 | |
| 43 | did | Digital input delay | OFF ÷ 99.59 min.sec | OFF | |
| 44 | PASS | Access password to the operational parameters | OFF ÷ 9999 | OFF | |
| 45 | SPd | Differential Set Point | SPLL ÷ SPHL | 0.0 | |

6 - PROBLEMS, MAINTENANCE AND GUARANTEE

6.1 - SIGNALLING

Error Signalling:

| Error | Reason | Action |
|-------------------------|--|---|
| E1 -E1 | The probe Pr1 may be interrupted or in short circuit, or may measure a value outside the range allowed | Check the correct connection of the probe with the instrument and check the probe works correctly |
| E2 -E2 | The probe Pr2 may be interrupted or in short circuit, or may measure a value outside the range allowed | |
| EEPr | Internal memory error | Check and if necessary re-programme the parameters function. |

Other Signalling:

| Message | Reason |
|-------------|---|
| od | Delay in switching on in progress |
| HI 1 | Maximum Pr1 temperature alarm in progress |
| LO 1 | Minimum Pr1 temperature alarm in progress |
| HI 2 | Maximum Pr2 temperature alarm in progress |
| LO 2 | Minimum Pr2 temperature alarm in progress |
| On | Manual forcing ON Out Output |
| OFF | Manual forcing OFF Out Output |

6.2 - CLEANING

We recommend cleaning of the instrument with a slightly wet cloth using water and not abrasive cleaners or solvents which may damage the instrument.

6.3 - GUARANTEE AND REPAIRS

The instrument is under warranty against manufacturing flaws or faulty material, that are found within 12 months from delivery date.

The guarantee is limited to repairs or to the replacement of the instrument.

The eventual opening of the housing, the violation of the instrument or the improper use and installation of the product will bring about the immediate withdrawal of the warranty's effects.

In the event of a faulty instrument, either within the period of warranty, or further to its expiry, please contact our sales department to obtain authorisation for sending the instrument to our company.

The faulty product must be shipped to TECNOLOGIC with a detailed description of the faults found, without any fees or charge for Tecnologic, except in the event of alternative agreements.

7 - TECHNICAL DATA

7.1 - ELECTRICAL DATA

Power supply: 12, 24 VAC/VDC, 100..240 VAC +/- 10%

Frequency AC: 50/60 Hz

Power consumption: 5 VA approx.

Input/s: 2 inputs for temperature probes: PTC (KTY 81-121, 990 Ω @ 25 °C) or NTC (103AT-2, 10KΩ @ 25 °C).

Output/s: up to 3 relay outputs. OUT1: SPST-NO (16A-AC1, 6A-AC3 250 VAC, 1HP 250VAC, 1/2HP 125 VAC) o SPDT (16A-AC1-NO, 8A-AC1-NC, 6A-AC3 250 VAC, 1HP 250VAC, 1/2HP 125 VAC); OUT2 and 3: SPDT (8A-AC1, 3A-AC3 250 VAC, 1/2HP 250VAC, 1/3HP 125 VAC).

Electrical life for relay outputs: OUT1 SPST-NO: 100000 op. ; OUT1 SPDT: 50000 op. (om. VDE); OUT2,3: 100000 op.

Installation category: II

Measurement category: I

Protection class against electric shock: Class II for Front panel

Insulation: Reinforced insulation between the low voltage part (supply H type and relay outputs) and front panel; Reinforced insulation between the low voltage section (supply type H and relay outputs) and the extra low voltage section (inputs); Reinforced between supply and relay outputs; No insulation between supply F type and inputs.

7.2 - MECHANICAL DATA

Housing: Self-extinguishing plastic, UL 94 V0

Dimensions: 4 DIN modules 70 x 84 mm, depth 60 mm

Weight: 180 g approx.

Mounting: Enclosure on DIN OMEGA rail

Connections: 2,5 mm² screw terminals block

Degree of front panel protection : IP 40 (terminals IP20)

Pollution situation: 2

Operating temperature: 0 T 50 °C

Operating humidity: < 95 RH% without condensation

Storage temperature: -10 T 60 °C

7.3 - MECHANICAL DIMENSIONS [mm]

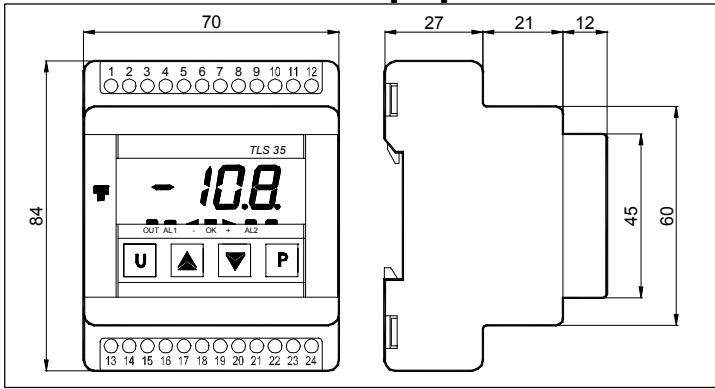

7.4 - FUNCTIONAL FEATURES

Temperature Control: ON/OFF mode

Measurement range: PTC: -50 T 150 °C / -58 T 199 °F; NTC: -50 T 109 °C / -58 T 199 °F

Differential measurement range: -360 T 360 / -99.9 T 360

Display resolution: 1 ° or 0,1°

Overall accuracy: +/- (0,5 % fs + 1 digit)

Sampling rate: 130 ms.

Display: 4 Digit Red h 12 mm

Compliance: ECC directive EMC 2004/108/CE (EN 61326), ECC directive LV 2006/95/CE (EN 61010-1)

7.5 - INSTRUMENT ORDERING CODE

TLS 35 a b c d ee f

a : POWER SUPPLY

H = 100...240 VAC

L = 24 VAC/VDC

F = 12 VAC/VDC

b : OUTPUT OUT1

S = Relay SPDT 16A-AC1

R = Relay SPST-NO 16A-AC1

c : OUTPUT OUT2

- = None

R = Relay

d : OUTPUT OUT3

- = None

R = Relay

ee: SPECIAL CODES

f: SPECIAL VERSIONS